

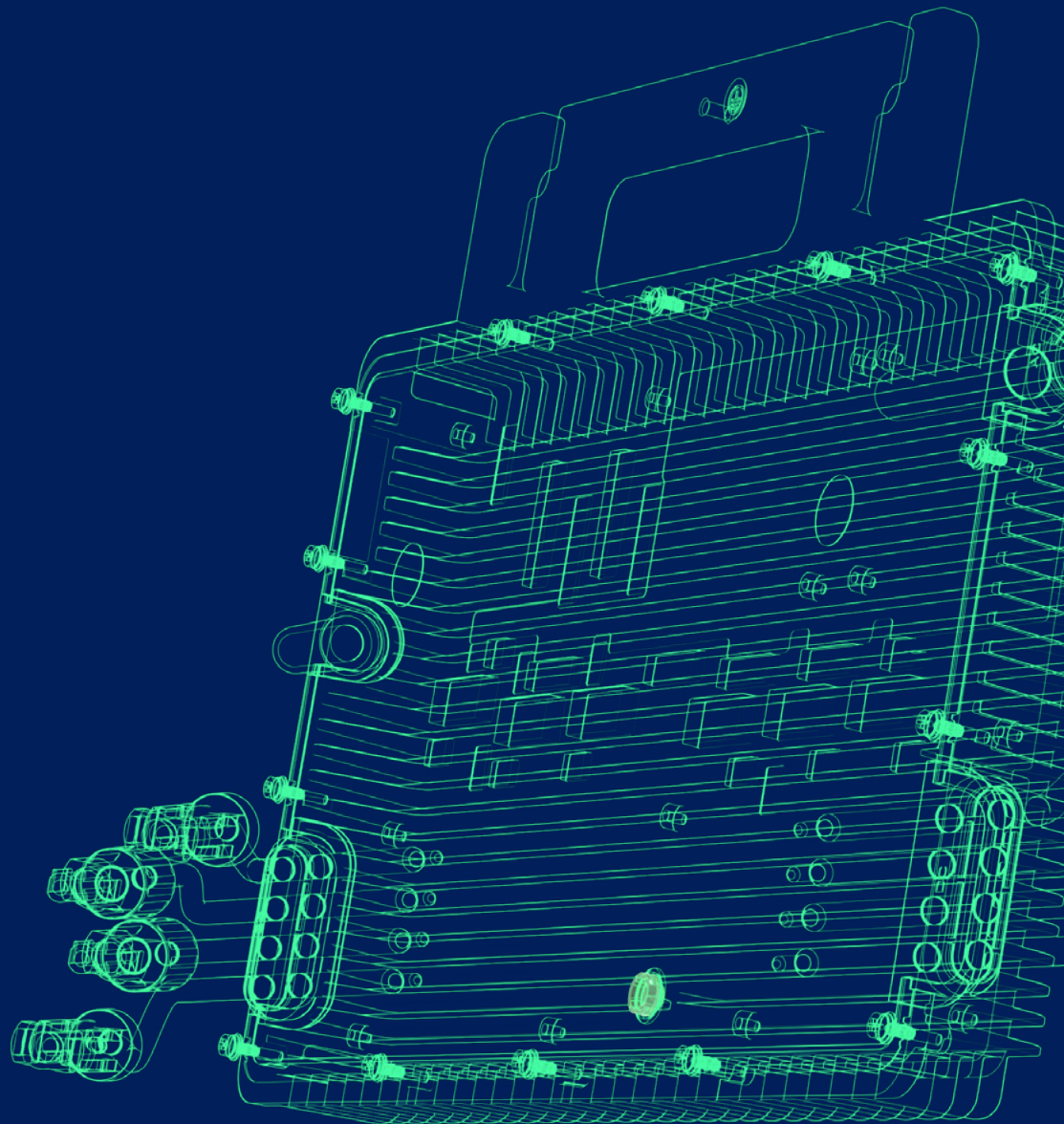

PRODUCT BROCHURE 2023

FOR **APAC & Africa**



Open Energy For All

Bringing smart solar to the entire world with rugged technology

Hoymiles' mission is to become the leading choice for getting started with smart energy, making good technology more impactful by ensuring it's accessible to everyone, and bringing smart solar to the entire world with high-quality products.

Hoymiles is a global MLPE (Module Level Power Electronics) solution provider, specializing in module-level inverters and storage systems. With a vision of a clean, sustainable future, we strive to lead the smart energy industry through our rugged technology and reliable products.

With our driven engineer team, 1200+ global experts and distribution & service network spanning North America, South America, Europe, Asia, Africa and Oceania, Hoymiles has empowered homeowners and professionals in more than 100 countries and regions to join the journey to true open energy.

Hoymiles officially debuted on the Shanghai Stock Exchange STAR Market in Dec. 2021 under the stock code 688032. Now we are favored by the market as a trustworthy partner to our investors, installers and end consumers.

Product Portfolio

Microinverter

Single-phase | HMS Series

- 06 · HMS-400 / HMS-450 / HMS-500-1T
- 08 · HMS-800 / HMS-900 / HMS-1000-2T
- 10 · HMS-1600 / HMS-1800 / HMS-2000-4T
- 12 · HMS-1600D / HMS-1800D / HMS-2000D-4T

Accessories

- 14 · HMS Cable Accessories

Three-phase | HMT Series

- 18 · HMT-1600 / HMT-1800 / HMT-2000-4T

Accessories

- 20 · HMT Cable Accessories

Data Transfer Unit

- 22 · DTU-Pro-S
- 24 · DTU-Lite-S

Energy Storage Inverter

Hybrid Inverter

- 26 · HYS-3.0LV / HYS-3.6LV / HYS-4.6LV / HYS-5.0LV / HYS-6.0LV-EUG1
- 28 · HYT-5.0HV / HYT-6.0HV / HYT-8.0HV / HYT-10.0HV / HYT-12.0HV-EUG1

AC-coupled Inverter

- 30 · HAS-3.0LV / HAS-3.6LV / HAS-4.6LV / HAS-5.0LV-EUG1
- 32 · HAT-5.0HV / HAT-6.0HV / HAT-8.0HV / HAT-10.0HV-EUG1

Data Transfer Stick

- 34 · DTS-G1

Rapid Shutdown Device

- 38 · HRSD-1C Series
- 40 · HRSD-2C Series

Transmitter

- 42 · HT10-Kit

Project Success

Our Products

When you choose Hoymiles, you're choosing a neat set of advantages. Our products have a low failure rate, high-efficiency in converting DC to AC, are of the highest industry quality, and are incredibly easy to install.

Increased Return on Investment

- Easily install units in challenging conditions and positions
- Low start-up voltage

Smarter

- Module-level monitoring for remote troubleshooting & maintenance

More Efficient

- World's leading power density
- Leading MPPT efficiency: 99.8%

Installer Friendly

- Full product range: 1-1 to 4-1, 400W-2000W
- High cost effective (LCOE)
- Plug-and-play, easy installation
- Extensive warranty

Safer

- Up to 60V DC input voltage to eliminate the risk of a rooftop fire
- IP67

More Reliable

- Low failure rate (0.18%)
- Global compliant: EN50549-1:2019 and California Rule 21





Single-phase Microinverter 1 in 1

HMS-400-1T
HMS-450-1T
HMS-500-1T

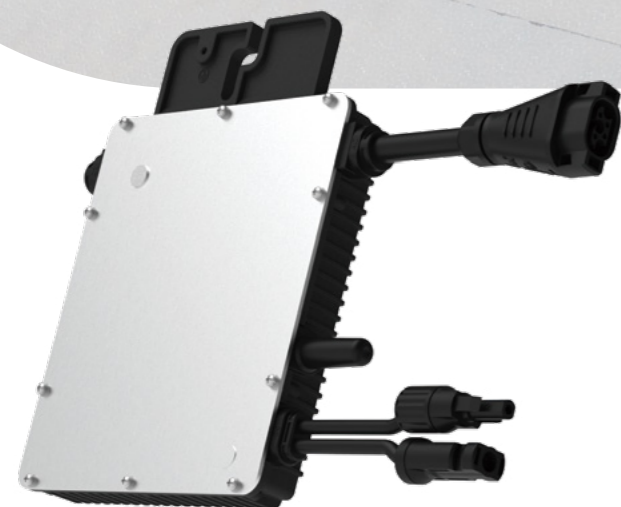

With the output power up to 500 VA, Hoymiles new microinverter HMS-500 series rank among the highest for 1-in-1 microinverters.

Each microinverter connects to 1 PV module with independent MPPT and monitoring, ensuring greater energy harvest and easier maintenance.

The new Sub-1G wireless solution enables more stable communication under various environmental conditions.

✓ High-powered microinverter for 1-in-1 with output power up to 500 VA

✓ With Reactive Power Control, compliant with EN 50549-1:2019, VDE-AR-N 4105:2018, UL 1741, etc.

✓ Connected to one panel, flexible for various applications

✓ Safer for rooftop solar stations with rapid shutdown compliance and isolated transformer

✓ Sub-1G wireless solution allows stable communication with Hoymiles gateway DTU

Technical Specifications

Model	HMS-400-1T			HMS-450-1T			HMS-500-1T		
Input Data (DC)									
Commonly used module power (W)	320 to 540+			360 to 600+			400 to 670+		
Maximum input voltage (V)	65								
MPPT voltage range (V)	16-60								
Start-up voltage (V)	22								
Maximum input current (A)	14			15			16		
Maximum input short circuit current (A)	25								
Number of MPPTs	1								
Number of Inputs per MPPT	1								
Output Data (AC)									
Rated output power (VA)	400			450			500		
Rated output current (A)	1.82	1.74	1.67	2.05	1.96	1.88	2.27	2.17	2.08
Nominal output voltage/range (V) ¹	220/180-275	230/180-275	240/180-275	220/180-275	230/180-275	240/180-275	220/180-275	230/180-275	240/180-275
NNominal frequency/range (Hz) ¹	50/45-55 or 60/55-65								
Power factor (adjustable)	> 0.99 default 0.8 leading ... 0.8 lagging								
Total harmonic distortion	< 3%								
Maximum units per 10AWG branch ²	17	18	19	15	16	17	14	14	15
Maximum units per 12AWG branch ²	11	11	12	9	10	10	8	9	9
Efficiency									
CEC peak efficiency	96.5%								
Nominal MPPT efficiency	99.8%								
Night power consumption (mW)	< 50								
Mechanical Data									
Ambient temperature range (°C)	-40 to +65								
Dimensions (W × H × D mm)	182 × 164 × 30								
Weight (kg)	1.75								
Enclosure rating	Outdoor-IP67 (NEMA 6)								
Cooling	Natural convection-No fans								
Features									
Communication	Sub-1G								
Type of isolation	Galvanically Isolated HF Transformer								
Monitoring	Hoymiles S-Miles Cloud ³								
Compliance	EN 50549-1: 2019, VDE-AR-N 4105: 2018, UL 1741, IEC/EN 62109-1/-2, IEC/EN 61000-6-1/-2/-3/-4, IEC/EN 61000-3-2/-3								

*1 Nominal voltage/frequency range can vary depending on local requirements.

*2 Refer to local requirements for exact number of microinverters per branch.

*3 Hoymiles Monitoring System



Single-phase Microinverter 2 in 1

HMS-800-2T
HMS-900-2T
HMS-1000-2T

With the output power up to 1000 VA, Hoymiles new microinverter HMS-1000 series rank among the highest for 2-in-1 microinverters.

Each microinverter can connect up to 2 panels, with independent MPPT and monitoring maximizing the power production of your installation.

The new Sub-1G wireless solution enables more stable communication with Hoymiles gateway DTU.



- ✓ High-powered microinverter for 2-in-1 with output power up to 1000 VA
- ✓ Safer for rooftop solar stations with rapid shutdown compliance and isolated transformer
- ✓ With Reactive Power Control, compliant with EN 50549-1:2019, VDE-AR-N 4105:2018, UL 1741, ABNT NBR 16150, etc.

- ✓ Independent MPPT and monitoring ensure greater energy harvest and easier maintenance
- ✓ 2-in-1 design enables faster installation
- ✓ Sub-1G wireless solution allows stable communication in commercial and industrial settings

Technical Specifications

Model	HMS-800-2T			HMS-900-2T			HMS-1000-2T		
Input Data (DC)									
Commonly used module power (W)	320 to 540+			360 to 600+			400 to 670+		
Maximum input voltage (V)	65								
MPPT voltage range (V)	16-60								
Start-up voltage (V)	22								
Maximum input current (A)	2 × 14			2 × 15			2 × 16		
Maximum input short circuit current (A)	2 × 25								
Number of MPPTs	2								
Number of Inputs per MPPT	1								
Output Data (AC)									
Rated output power (VA)	800			900			1000		
Rated output current (A)	3.64	3.48	3.33	4.09	3.91	3.75	4.55	4.35	4.17
Nominal output voltage/range (V) ¹	220/180-275	230/180-275	240/180-275	220/180-275	230/180-275	240/180-275	220/180-275	230/180-275	240/180-275
Nominal frequency/range (Hz) ¹	50/45-55 or 60/55-65								
Power factor (adjustable)	> 0.99 default 0.8 leading...0.8 lagging								
Total harmonic distortion	< 3%								
Maximum units per 10AWG branch ²	8	9	9	7	8	8	7	7	7
Maximum units per 12AWG branch ²	5	5	6	4	5	5	4	4	4
Efficiency									
CEC peak efficiency	96.7%			96.5%			96.5%		
Nominal MPPT efficiency	99.8%								
Night power consumption (mW)	< 50								
Mechanical Data									
Ambient temperature range (°C)	-40 to +65								
Dimensions (W × H × D mm)	261 × 180 × 35.1								
Weight (kg)	3.2								
Enclosure rating	Outdoor-IP67 (NEMA 6)								
Cooling	Natural convection-No fans								
Features									
Communication	Sub-1G								
Type of isolation	Galvanically Isolated HF Transformer								
Monitoring	Hoymiles S-Miles Cloud ³								
Compliance	EN 50549-1: 2019, VDE-AR-N 4105: 2018, UL 1741, ABNT NBR 16150, IEC/EN 62109-1/-2, IEC/EN 61000-6-1/-2/-3/-4, IEC/EN 61000-3-2/-3								

*1 Nominal voltage/frequency range can vary depending on local requirements.

*2 Refer to local requirements for exact number of microinverters per branch.

*3 Hoymiles Monitoring System



**Single-phase
Microinverter 4 in 1**

**HMS-1600-4T
HMS-1800-4T
HMS-2000-4T**

With the output power up to 2000 VA, Hoymiles new microinverter HMS-2000 series rank among the highest for 4-in-1 microinverters.

Each microinverter can connect up to 4 panels, with independent MPPT and monitoring maximizing the power production of your installation.

The new Sub-1G wireless solution enables more stable communication with Hoymiles gateway DTU.

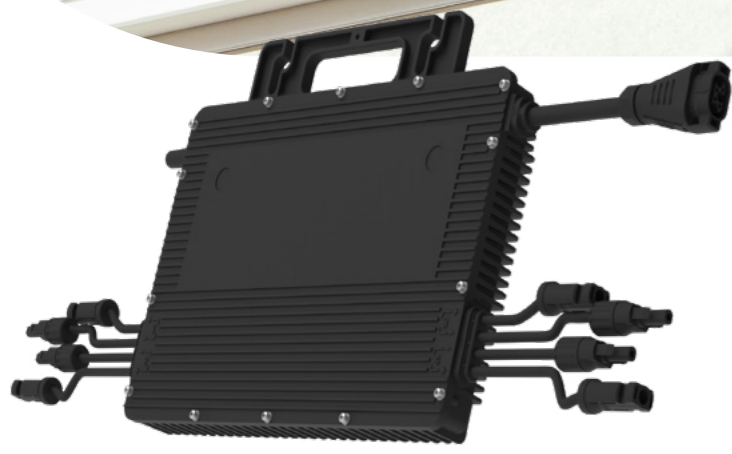

- ✓ High-powered microinverter with output power up to 2000 VA
- ✓ Independent MPPT and monitoring ensure greater energy harvest and easier maintenance
- ✓ With Reactive Power Control, compliant with EN 50549-1:2019, VDE-AR-N 4105:2018, UL 1741, ABNT NBR 16150, etc.
- ✓ 4-in-1 design enables faster installation and comes with a lower cost
- ✓ Safer for rooftop solar stations with rapid shutdown compliance and isolated transformer
- ✓ Sub-1G wireless solution allows stable communication in commercial and industrial settings

Technical Specifications

Model	HMS-1600-4T			HMS-1800-4T			HMS-2000-4T		
Input Data (DC)									
Commonly used module power (W)	320 to 540+			360 to 600+			400 to 670+		
Maximum input voltage (V)				65					
MPPT voltage range (V)				16-60					
Start-up voltage (V)				22					
Maximum input current (A)	4 × 14			4 × 15			4 × 16		
Maximum input short circuit current (A)				4 × 25					
Number of MPPTs				4					
Number of inputs per MPPT				1					
Output Data (AC)									
Rated output power (VA)	1600			1800			2000		
Rated output current (A)	7.27	6.96	6.67	8.18	7.83	7.5	9.09	8.7	8.33
Nominal output voltage/range (V) ¹	220/180-275	230/180-275	240/180-275	220/180-275	230/180-275	240/180-275	220/180-275	230/180-275	240/180-275
Nominal frequency/range (Hz) ¹				50/45-55 or 60/55-65					
Power factor (adjustable)				> 0.99 default 0.8 leading...0.8 lagging					
Total harmonic distortion				< 3%					
Maximum units per 10AWG branch ²	4	4	4	3	4	4	3	3	3
Efficiency									
CEC peak efficiency				96.5%					
Nominal MPPT efficiency				99.8%					
Night power consumption (mW)				< 50					
Mechanical Data									
Ambient temperature range (°C)				-40 to +65					
Dimensions (W × H × D mm)				331 × 218 × 40.6					
Weight (kg)				5.6					
Enclosure rating				Outdoor-IP67 (NEMA 6)					
Cooling				Natural convection-No fans					
Features									
Communication				Sub-1G					
Type of isolation				Galvanically Isolated HF Transformer					
Monitoring				S-Miles Cloud ³					
Compliance				EN 50549-1: 2019, VDE-AR-N 4105: 2018, UL 1741, ABNT NBR 16150, IEC/EN 62109-1/-2, IEC/EN 61000-6-1/-2/-3/-4, IEC/EN 61000-3-2/-3					

*1 Nominal voltage/frequency range can vary depending on local requirements.

*2 Refer to local requirements for exact number of microinverters per branch.

*3 Hoymiles Monitoring System



Single-phase Microinverter 4 in 1

HMS-1600D-4T
HMS-1800D-4T
HMS-2000D-4T

Hoymiles 4-in-1 microinverter HMS-2000D-4T features 4 input channels, significantly lowering installation costs.

All of these models listed are connected to an intelligent monitoring system to track individual modules' performance over time and offer superior energy production.

The new Sub-1G wireless solution enables more stable communication under various environmental conditions.



- ✓ High-powered microinverter with output power up to 2000 VA.
- ✓ 99.8% MPPT efficiency and module-level monitoring ensure greater energy harvest and easier maintenance.
- ✓ Comply with UL 1741, IEC 61727, IEC 62116, IEC 61683, ect.

- ✓ 4-in-1 design maximizes efficiency and reduces costs.
- ✓ Sub-1G wireless solution allows stable communication in commercial and industrial settings.
- ✓ IP67 (NEMA 6) protection degree, adapt to outdoor use.

Technical Specifications

Model	HMS-1600D-4T			HMS-1800D-4T			HMS-2000D-4T		
Input Data (DC)									
Commonly used module power (W)	320 to 540+			360 to 600+			400 to 670+		
Maximum input voltage (V)	65								
MPPT voltage range (V)	16-60								
Start-up voltage (V)	22								
Maximum input current (A)	4 × 14			4 × 15			4 × 16		
Maximum input short circuit current (A)	4 × 25								
Number of MPPTs	2								
Number of inputs per MPPT	2								
Output Data (AC)									
Rated output power (VA)	1600			1800			2000		
Rated output current (A)	7.27	6.96	6.67	8.18	7.83	7.50	9.09	8.70	8.33
Nominal output voltage/range (V) ¹	220/180-275	230/180-275	240/180-275	220/180-275	230/180-275	240/180-275	220/180-275	230/180-275	240/180-275
Nominal frequency/range (Hz) ¹	50/45-55 or 60/55-65								
Power factor (adjustable)	> 0.99 default 0.8 leading ... 0.8 lagging								
Total harmonic distortion	< 3%								
Maximum units per branch ²	4	4	4	3	4	4	3	3	3
Efficiency									
CEC peak efficiency	96.70%			96.50%			96.50%		
Nominal MPPT efficiency	99.80%								
Night power consumption (mW)	< 50								
Mechanical Data									
Ambient temperature range (°C)	-40 to +65								
Dimensions (W × H × D [mm])	310 × 185 × 40.6								
Weight (kg)	4.5								
Enclosure rating	Outdoor-IP67 (NEMA 6)								
Cooling	Natural convection – No fans								
Features									
Communication	Sub-1G								
Topology	Galvanically Isolated HF Transformer								
Monitoring	S-Miles Cloud ³								
Compliance	IEC 61727, IEC 62116, IEC 61683, IEC60068-2-1/-2/-14/-30, IEC/EN 62109-1/-2, IEC/EN 61000-6-1/-2/-3/-4, IEC/EN 61000-3-2/-3								

*1 Nominal voltage/frequency range can vary depending on local requirements.

*2 Refer to local requirements for exact number of microinverters per branch.

*3 Hoymiles Monitoring System

HMS Cable Accessories

SIMPLIFY YOUR INSTALLATION WITH EASY & FLEXIBLE & RELIABLE CABLE SYSTEM

The HMS cable system is a revolutionary cabling solution designed for the HMS series microinverters, which can be used in PV systems with either one or multiple microinverters. Its user-friendly plug-and-play design makes the installation easier, faster, and more reliable. The HMS cable system also features highly flexible, allowing users to mix and match HMS Connection Cables of different sizes or lengths to achieve their desired wiring configuration at the lowest cost.

Single-Microinverter System

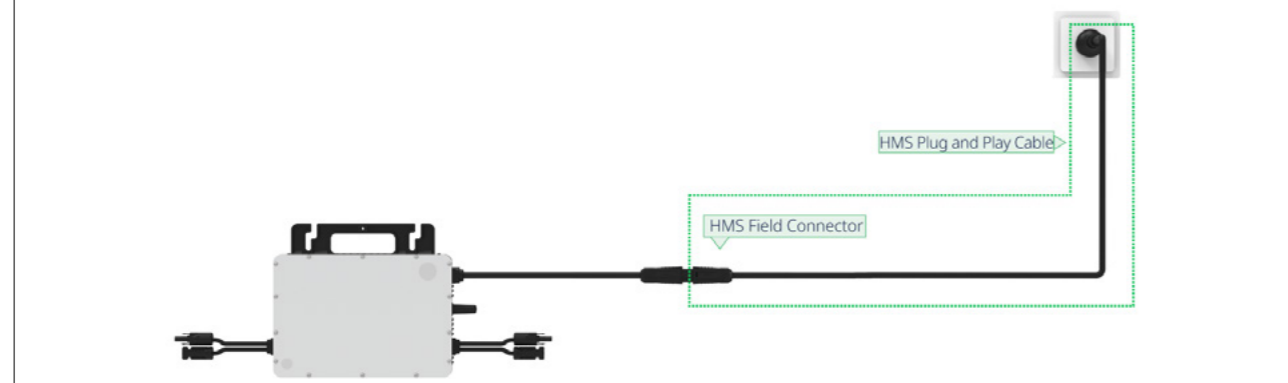

Multi-Microinverter System

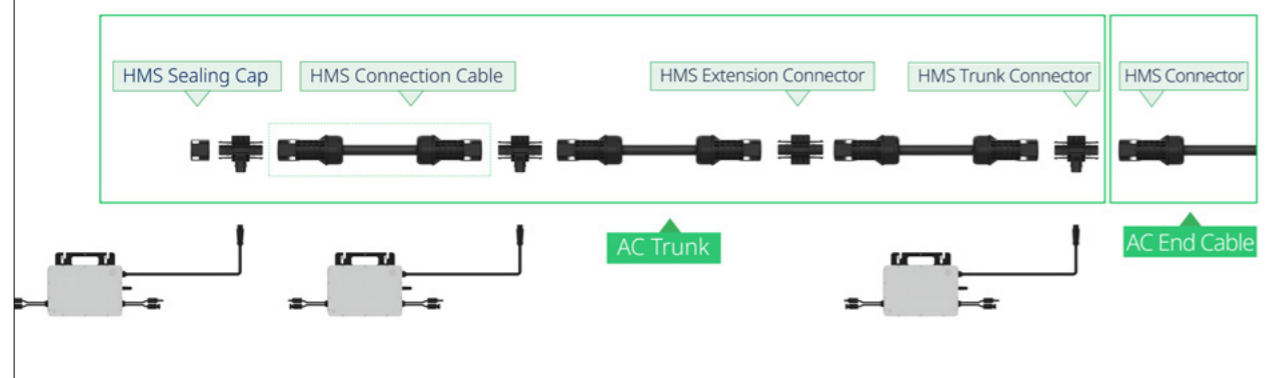

Time-saving & Cost-effective

- Plug-and-play design eliminates the need for complex wiring and crimping, cutting installation time by 70%
- Handle current up to 40 A, allowing more microinverters to be connected in series and lowering system costs

Compatibility

- Work seamlessly with the current HMS series microinverters

Flexibility

- Provide great flexibility for AC Trunk design that caters to the specific requirements of your PV system
- Work with HMS Connection Cables of different cable sizes

Reliability

- Improved internal design reduces connection resistance
- Plug-and-play assembly minimize the risk of errors during field installation

Single-Microinverter System

HMS Field Connector

HMS Field Connector is designed for the situation where a PV system only has one microinverter. It provides a quick and simple electrical connection between the microinverter and the grid by serving as a joining component.



HMS Plug and Play Cable

HMS Plug and Play Cable is designed for the situation where a PV system has only one microinverter. It consists of the HMS field connector, AC cable, and plug. The HMS field connector is connected to the microinverter, and the plug is connected to the household socket in accordance with local regulations.



Technical Specifications

HMS Field Connector Parameters

Pin number	2P + PE
Rated voltage	300 V
Rated current	12 A (Use 1.5 mm ² copper cable)
Applicable cable specification	1.0 / 1.5 mm ²
Wire hole diameter	2.6 mm
Applicable cable outer diameter	8 mm to 9.5 mm
Cable connection type	screw pressing
Ambient temperature range	-40°C to +85°C
Dimensions (L × W × H)	135 × 38 × 25 mm
Protection degree	IP68
Flame resistance degree	UL94-V0
Compliance	RoHS
Product standard	PPP 59015A: 2013

HMS Plug and Play Cable Parameters

Consisting components	HMS Field Connector + Cable + AC plug
Cable type	PV07AC-F
Conductors cross-sectional area	1.5 mm ²
Cable outer diameter	9.3±0.40 mm
Minimum bending radius	5 cm
AC Plug standard	CEE 7/7
Rated voltage	250 V
Rated current	12 A
Ambient temperature range	-40°C to +85°C
Compliance	RoHS
Product standard	PPP 59015A: 2013 (Connector) / TÜV 2 PFG 1940 (Cable) / VDE 0620 (Plug)

Ordering Options

Model	Cable Length Between Connector and AC Plug	Number per Box	Box Dimensions (mm)
HMS Field Connector	\	300	495 × 290 × 255
HMS Plug and Play Cable-CEE7/7-3m	3.0 m (customizable)	25	495 × 290 × 255

Multi-Microinverter System

HMS Connection Cable

Make a customized AC Trunk by utilizing HMS Trunk Connectors and HMS Extension Connectors.



HMS Trunk Connector

Used to connect the microinverter's AC output to the AC Trunk, as well as to join together multiple HMS Connection Cables to create the AC Trunk.



HMS Connector

Used to form the AC cable into an AC End Cable, which completes the connection between the end of the AC Trunk and the distribution box.



HMS Extension Connector

Used to extend your cable runs when the distance between two microinverters exceeds the standard length of an HMS Connection Cable.



HMS Sealing Cap

Used to cover the unused connection port on the HMS Trunk Connector, which is typically located at the beginning of the AC Trunk.



HMS Disconnect Tool

A versatile tool that can be used to take apart connectors, tighten nuts, and loosen nuts.



Technical Specifications

Connector System Parameter

Pin number	2P + PE
Rated voltage	300 V
Rated current	40 A
Max. supported conductor sizes	6.0 mm ²
Max. supported cable outer diameter	16.5 mm
Ambient temperature range	-40°C to +85°C
Protection degree	IP68
Flame resistance degree	UL94-V0
Compliance	RoHS
Product standard	IEC 61984

Cable System Parameter

Cable type	H07RN-F
Rated voltage	450 V
Conductor size	2.5 mm ² / 4.0 mm ² / 6.0mm ²
UV exposure rating	According to 2PFG 1940

Cable flame rating	According to IEC 60332-1-2
Ambient temperature range	-40°C to +90°C
Compliance	RoHS
Product standard	EN50525-2-21

Connector Ordering Options

Connector Model	Number per Box	Box Dimensions (mm)
HMS Sealing Cap	TBD	495 × 290 × 255
HMS Trunk Connector	TBD	495 × 290 × 255
HMS Extension Connector	TBD	495 × 290 × 255
HMS Disconnection Tool	TBD	495 × 290 × 255
HMS Connector	TBD	495 × 290 × 255

Connection Cable Model	Conductors Cross Sectional Area	Rated Current @55 °C ¹	Cable Length Between Connectors ²	Minimum Bending Radius	Number Per Box	Box Dimensions
HMS Connection Cable-ENH25-110	3 x 2.5 mm ²	24 A	1.1 m	6 cm	TBD	495 × 290 × 255 mm
HMS Connection Cable-ENH25-200	3 x 2.5 mm ²	24 A	2.0 m	6 cm	TBD	495 × 290 × 255 mm
HMS Connection Cable-ENH25-230	3 x 2.5 mm ²	24 A	2.3 m	6 cm	TBD	495 × 290 × 255 mm
HMS Connection Cable-ENH25-460	3 x 2.5 mm ²	24 A	4.6 m	6 cm	TBD	495 × 290 × 255 mm
HMS Connection Cable-ENH40-110	3 x 4.0 mm ²	32 A	1.1 m	7 cm	TBD	495 × 290 × 255 mm
HMS Connection Cable-ENH40-200	3 x 4.0 mm ²	32 A	2.0 m	7 cm	TBD	495 × 290 × 255 mm
HMS Connection Cable-ENH40-230	3x 4.0 mm ²	32 A	2.3 m	7 cm	TBD	495 × 290 × 255 mm
HMS Connection Cable-ENH40-460	3 x 4.0 mm ²	32 A	4.6 m	7 cm	TBD	495 × 290 × 255 mm
HMS Connection Cable-ENH60-110	3 x 6.0 mm ²	40 A	1.1 m	8 cm	TBD	495 × 290 × 255 mm
HMS Connection Cable-ENH60-200	3 x 6.0 mm ²	40 A	2.0 m	8 cm	TBD	495 × 290 × 255 mm
HMS Connection Cable-ENH60-230	3 x 6.0 mm ²	40 A	2.3 m	8 cm	TBD	495 × 290 × 255 mm
HMS Connection Cable-ENH60-460	3 x 6.0 mm ²	40 A	4.6 m	8 cm	TBD	495 × 290 × 255 mm

1) Rated Current @55 °C: The given value is typical at 55°C temperature and may differ at different temperatures. To calculate the actual current carrying capacity of the cable at other temperatures, refer to the technical note 'Ampacity Calculation Guide for Hoymiles HMS Cable System'. Please comply with local standards when designing and installing cables.

2) Cable length can be customized. Please contact Hoymiles sales for more details.



Three-phase Microinverter 4 in 1

HMT-1600-4T
HMT-1800-4T
HMT-2000-4T

Hoymiles new generation microinverter HMT-2000 series is designed to accommodate the high-powered PV modules, with maximum output power up to 2000 VA and maximum DC input current up to 16 A.

The innovative 4-input design enables faster installation and lower cost, and makes HMT-2000 series a very cost-effective choice.

The new Sub-1G wireless solution enables more stable communication with Hoymiles gateway DTU.

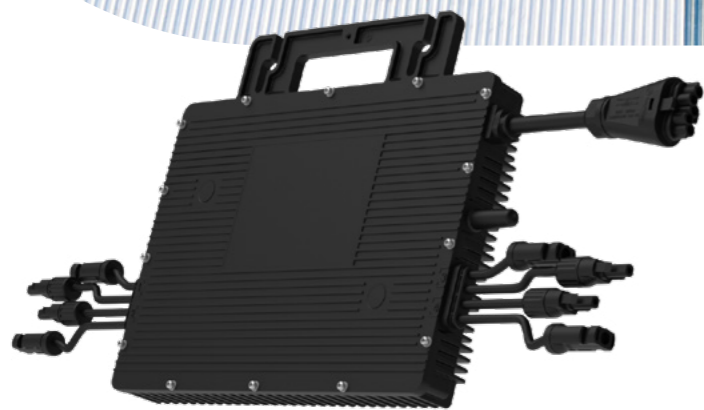

✓ Three-phase output, more suitable for commercial and industrial applications

✓ With output power up to 2000 VA, compatible with 182 mm/210 mm PV module

✓ Grid protection relay integrated

✓ 4-in-1 design enables faster installation and comes with a lower cost

✓ Safer for rooftop solar stations with rapid shutdown compliance and isolated transformer

✓ Sub-1G wireless solution allows stable communication in commercial and industrial settings

Technical Specifications

Model	HMT-1600-4T	HMT-1800-4T	HMT-2000-4T
Input Data (DC)			
Commonly used module power (W)	320 to 540+	360 to 600+	400 to 670+
Maximum input voltage (V)	65		
MPPT voltage range (V)	16-60		
Minimum/Maximum start-up voltage(V)	22/60		
Maximum input current (A)	4 × 14	4 × 15	4 × 16
Maximum input short circuit current (A)	4 × 25		
Number of MPPTs	2		
Number of inputs per MPPT	2		
Output Data (AC)			
Grid Type	Three Phase		
Rated output power (VA)	1600	1800	2000
Rated output current (A)	2.32 × 3	2.61 × 3	2.9 × 3
Nominal output voltage (V)	230/400, 3W+N+PE		
Nominal frequency (Hz)	50		
Power factor (adjustable)	> 0.99 default		
Total harmonic distortion	< 3%		
Maximum units per 12 AWG branch ¹	8	7	6
Maximum units per 10 AWG branch ¹	13	12	11
Efficiency			
CEC peak efficiency	96.50%		
Nominal MPPT efficiency	99.80%		
Night power consumption (mW)	< 50		
Mechanical Data			
Ambient temperature range (°C)	-40 to +65		
Storage temperature range (°C)	-40 to +85		
Dimensions (W × H × D [mm])	326 × 222 × 40.6		
Weight (kg)	5.9		
Enclosure rating	Outdoor-IP67		
Cooling	Natural convection-No fans		
Features			
Communication	Sub-1G		
Type of isolation	Galvanically Isolated HF Transformer		
Monitoring	S-Miles Cloud ²		
Compliance	VDE-AR-N 4105: 2018, EN 50549-1:2019, VFR 2019, IEC/EN 62109-1/-2, IEC/EN 61000-6-1/-2/-3/-4, IEC/EN 61000-3-2/-3		

*1 Refer to local requirements for exact number of microinverters per branch.

*2 Hoymiles Monitoring System

Cable Accessories for Microinverter of HMT Series

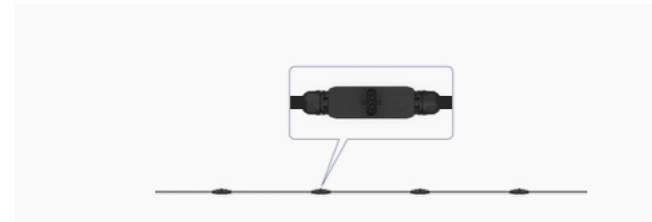

3P-AC Trunk Cable, 12/10 AWG Cable

3P-AC Trunk Cable is used to connect the microinverter to distribution box.

The Trunk Connector on the 3P-AC Trunk Cable is evenly distributed at intervals, Hoymiles provides 3P-AC Trunk Cable with different AC Trunk Connector spacing.



3P-AC Trunk Connector

The AC Sub Connector of the microinverter can be inserted into the port of the 3P-AC Trunk Connector. Plug and play connectors speed up and simplify installation.



3P-AC Trunk Port Cap

Used to protect vacant AC Trunk Port.

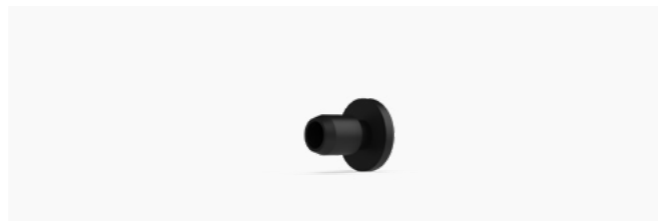

3P-AC Trunk End Cap

Used to protect the cable port of 3P-AC Trunk Connector at the end of the 3P-AC branch.



3P-AC Trunk Port Disconnect Tool

Used to disconnect the connection between the microinverter and the 3P-AC Trunk Connector.



3P-AC Trunk Connector Unlock Tool

Used to unlock the 3P-AC Trunk Connector upper cover so that the cable can be removed, replaced, and the 3P-AC Trunk End Cap installed.



DC Extension Cable

Connect the microinverter and the PV module when the distance between the two exceeds the original cable length.

Technical Specifications

3P-AC Trunk Cable	
Model	
Main Parameters	
Cable type	10 AWG
Rated voltage	600 V
Cable outer diameter	15.8±0.50 mm
Ambient temperature range	-40°C to +90°C
AC Trunk Connector spacing	3.05 m
Number of AC Trunk Connectors per single AC Trunk Cable	14
Single AC Trunk Cable length	45.5 m
Compliance	
Product standard	UL 44, UL 1277, UL 1581
RoHS compliant	Yes

3P-AC Trunk Connector	
Model	
Main Parameters	
Pin number	3P+N+PE
Rated current	32 A (Use 10 AWG/6mm ² copper cable)
Rated voltage	500 V
Contact resistance	≤5 mΩ
Power frequency withstand voltage	3000 V AC
Over voltage type	III
Connection Parameter	
Applicable cable specification	12/10 AWG
Applicable cable outer diameter	13 mm to 18 mm
Cable connection type	Screw pressing
Sub connector connection type	Crimping
Mechanical Data	
Ambient temperature range	-40°C to +85°C
Dimensions (L × W × H mm)	200 × 45 × 120
Protection rating	IP68
Flame resistance degree	UL 94-V0
Compliance	
Product standard	2PFG1915 ANSI/UL 6703-2017
RoHS compliant	Yes

DC Extension Cable		
Model		
Cable		
Cable type	PV1-F 1X4	
Rated current	20 A	
Rated voltage	Max.1800V DC	
Cable length	1 m	
Ambient temperature range	-40°C to +90°C	
Product standard	2 PFG 1169/08.2007	
DC Connector		
Manufacturer	Betteri	Staubli
Type	BC03A, BC03B	PV-KBT4/6II-UR
Rated current	30 A	39 A (TUV), 30 A (UL)
Rated voltage	1000 V DC (TUV), 600/1000 V DC (CSA)	1000 V DC (TUV), 1500 V DC (UL)
Rated impulse withstand voltage	6000 V	12000 V
Over voltage category		III
Ambient temperature range	-40°C to +85°C	-40°C to +85°C (TUV), -40°C to +75°C (UL)
Protection rating	IP67	IP68
Flame resistance degree		UL 94-V0
Product standard	EN 62852:2014 UL 6703	EN 62852 UL 6703 2PFG2330 CNCA/CTS0002-2012
RoHS compliant		Yes



Data Transfer Unit

DTU-Pro-S

Compatible with HMS/HMT series

Hoymiles gateway DTU-Pro-S is a data transfer unit which collects information and data of PV microinverter using Sub-1G wireless solution and sends them to S-Miles Cloud, Hoymiles Monitoring Platform, using different communication options such as Ethernet, Wi-Fi or 4G.

With DTU-Pro-S, users can easily read module-level data and alarm, realize remote operation and maintenance of PV system at any time, from anywhere on S-Miles Cloud.



✓ Reliable and Flexible

- Sub-1G wireless solution enables stable communication with HMS, HMT series of microinverter
- More communication options with Ethernet, Wi-Fi or 4G
- Support of RS485, Ethernet to communicate with peripherals

✓ Simple and Efficient O&M

- Module-level monitoring and data storage
- Local configuration with S-Miles Toolkit
- Support remote O&M including remote upgrading, parameter setting

✓ Smart

- Smart zero export control and power export limiting
- PV generation and load consumption monitoring

Technical Specifications

Model	DTU-Pro-S (Wi-Fi Version)	DTU-Pro-S (4G Version)
Communication to Microinverter		
Signal		Sub-1G
Maximum distance (open space)		400 m
Monitoring data limit from solar panels ¹		99
Communication to S-Miles Cloud		
Ethernet		RJ45 × 1, 100Mbps
Wireless ²	Wi-Fi: 802.11b/g/n	4G: TDD-LTE, FDD-LTE 3G: SCDMA 2G: GSM/GPRS
Sample rate		Per 15 minutes
Communication to Peripherals		
RS485		COM × 1, 9600bps, Modbus-RTU
Ethernet		RJ45 × 1, Modbus-TCP
DRM (For AU/NZ only)		RJ45 × 1, DRM0/5/6/7/8
Interaction		
LED		LED Indicator × 4 – RUN, Cloud, MI, ALM
APP		S-Miles Toolkit
Power Supply (Adapter)		
Type		External adapter
Adapter input voltage/frequency		100 to 240 V AC/50 or 60 Hz
Adapter output voltage/current		5 V/2 A
Power consumption	Typ. 1.5 W / Max. 3.0 W	Typ. 2.5 W / Max. 5.0 W
Mechanical Data		
Ambient temperature (°C)		-20 to +55
Dimensions (W × H × D mm)		200 × 101 × 29 (without antennas)
Weight (kg)		0.20
Installation method		Wall mounting / Desktop mounting
Environmental rating		Indoor-IP20
Compliance		
Certificates		CE, FCC, IC, RCM, Anatel
Microinverter Compatibility		
Microinverter model		HMS series, HMT series

*1 This depends on the installation environment. Please refer to user manual for more details.

*2 Extended antenna is recommended if the DTU is installed inside a metal box or under a metal/concrete roof.



Data Transfer Unit DTU-Lite-S

Hoymiles gateway DTU-Lite-S is a data transfer unit which collects information and data of PV microinverter via Sub-1G wireless solution and sends them to S-Miles Cloud, Hoymiles Monitoring Platform, using Wi-Fi communication.

With small size and easy installation, DTU-Lite-S is suitable for residential PV systems. Users can easily read module-level data and alarms, realize remote operation and maintenance of the microinverter system at any time and any place on S-Miles Cloud.



✔ Module-level monitoring and data storage

✔ Sub-1G wireless solution with microinverter

✔ Plug and play, easy installation

✔ Real-time microinverter data and alarm on S-Miles Toolkit

✔ Remote system management on S-Miles Cloud

Technical Specifications

Model	DTU-Lite-S
Communication to Microinverter	
Type	Sub-1G
Maximum distance (open space)	400 m
Monitoring data limit from solar panels ¹	99
Communication to S-Miles Cloud	
Signal	802.11b/g/n
Sample rate	Per 15 minutes
Interaction	
LED	LED Indicator
Local App	S-Miles Toolkit
Power Supply (Adapter)	
Type	External adapter
Adapter input voltage/frequency	100 to 240 V AC / 50 or 60Hz
Adapter output voltage/current	5V / 2A
Power consumption (DTU)	Typ. 1.0W / Max. 5.0W
Mechanical Data	
Ambient temperature range (°C)	-20 to +55
Dimensions (W × H × D mm)	143 × 33 × 12.5
Weight (kg)	0.1
Installation option	Direct plug-in
Compliance	
Certificate	CE, FCC, IC, RCM, Anatel
Microinverter Compatibility	
Microinverter model	HMS series, HMT series

*1 This depends on the installation environment. Please refer to user manual for more details.



Single-phase Hybrid Inverter

HYS-3.0LV-EUG1
HYS-3.6LV-EUG1
HYS-4.6LV-EUG1
HYS-5.0LV-EUG1
HYS-6.0LV-EUG1

The HYS-LV Series is a high-performance single-phase hybrid inverter with excellent reliability, including power classes ranging from 3 kW to 6 kW.

The intelligent EMS function supports self-consumption mode, economic mode, and backup mode for multi-scenario applications.

Monitoring management through S-Miles Cloud allows users to remotely diagnose and track system's performance over time, maximizing the total solar power production and battery utilization.



- ✔ Intelligent export limitation
- ✔ DC/AC ratio up to 150%
- ✔ Double MPPT tracker, up to 14 A MPPT current
- ✔ Ultralight for easy installation and space-saving
- ✔ Compatible with multiple batteries, providing users with more choices
- ✔ Built-in dry contact flexibly set to earth fault alarm, load control or generator control
- ✔ UPS level switching time <10 ms
- ✔ Max. 10 parallel inverters

Technical Specifications

Model	HYS-3.0LV-EUG1	HYS-3.6LV-EUG1	HYS-4.6LV-EUG1	HYS-5.0LV-EUG1	HYS-6.0LV-EUG1
Battery					
Battery Type	Li-ion / Lead-acid				
Nominal Battery Voltage (V)	48				
Voltage Range (V)	40-60				
Max. Charge Current (A)	75	90	100	100	100
Max. Discharge Current (A)	75	90	100	100	100
Charging Strategy for Li-ion Battery	Self-adaption to BMS				
Charging Curve	3 Stages / Equalization				
External Temperature Sensor	Optional				
PV Input					
Max. PV Input Power (W)	4500	6000	7500	7500	7500
Max. PV Input Voltage (V)	550				
Nominal Input Voltage (V)	360				
MPPT Voltage Range (V)	125-500				
Start-up Voltage (V)	150				
Number of MPPTs	1	2	2	2	2
Max. Number of PV String per MPPT	1	1/1	1/1	1/1	1/1
Max. PV Input Current (A)	14	14/14	14/14	14/14	14/14
Short-circuit Current of PV Input (A)	17	17/17	17/17	17/17	17/17
AC Input and Output (On-grid)					
Nominal Output Apparent Power (VA)	3000	3680	4600	5000 ⁽¹⁾	6000 ⁽¹⁾
Max. Output Apparent Power (VA)	3000	3680	4600 ⁽²⁾	5000 ⁽¹⁾⁽²⁾	6000 ⁽¹⁾⁽²⁾
Max. Input Apparent Power (VA)	6000	7360	7360	7360	7360
Nominal AC Voltage (V)	230				
Nominal Grid Frequency (Hz)	50/60				
Max. Output Current (A)	13.0	16.0	20.0	21.7	26.0 ⁽³⁾
Max. Input Current (A)	26.1	32.0	32.0	32.0	32.0
Power Factor	0.8 leading ... 0.8 lagging				
Total Harmonic Distortion(@nominal output)	<3%				
AC Output (Off-grid)					
Max. Output Apparent Power (VA)	3000	3680	4600	5000	6000
Peak Output Apparent Power (VA) ⁽⁴⁾	6000, 10s	7360, 10s	9200, 10s	10000, 10s	10000, 10s
Nominal AC Voltage (V)	230				
Nominal AC Frequency (Hz)	50/60				
Max. Output Current (A)	13.0	16.0	20.0	21.7	26.0
Total Harmonic Distortion (@ linear load)	<3%				
Efficiency					
Max. Efficiency	97.6%	97.6%	97.6%	97.6%	97.6%
Euro Efficiency	97.0%	97.0%	97.0%	97.0%	97.0%
Max. Battery to Load Efficiency	95.0%	95.0%	95.0%	95.0%	95.0%
MPPT Efficiency	99.9%	99.9%	99.9%	99.9%	99.9%
Protection					
Anti-islanding Protection	Integrated				
PV String Input Reverse Polarity Protection	Integrated				
Insulation Resistor Detection	Integrated				
Residual Current Monitoring Unit	Integrated				
AC Over Current Protection	Integrated				
AC Short Current Protection	Integrated				
AC Overvoltage and Undervoltage Protection	Integrated				
Surge Protection	DC Type II / AC Type III				
General					
Dimension (W × H × D [mm])	502 × 461 × 202				
Weight (kg)	24				
Mounting	Wall Mounting				
Operation Temperature (°C)	-25 to + 65 (>45, derating)				
Relative Humidity	0-95%, no condensing				
Altitude (m)	≤2000				
Cooling	Natural Convection				
Protection Degree	IP65				
Noise (dB [A])	<40				
User Interface	LED & App				
Communication with BMS	RS485, CAN				
Communication with Meter	RS485				
Communication Interface	RS485, Wi-Fi/Ethernet/4G (optional)				
Digital Input/Output	DRM, 1 × DI, 2 × DO				
Isolation Method (Solar / Battery)	Transformerless / High-frequency Isolation				
Certifications and Standards					
Grid Regulation	EN 50549, VDE-AR-N 4105, AS/NZS 4777.2, VFR: 2019, TOR Erzeuger Type A, RD647, NTS (SENP), CEI 0-21 2019:04				
Safety Regulation	IEC 62109-1, IEC 62109-2				
EMC	EN 61000-6-1, EN 61000-6-3				

(1) 4600 for VDE-AR-N 4105 & VDE0126-1-1; 4999 for AS/NZS 4777.2
(2) Max. output apparent power 3680 VA for TOR Erzeuger Type A
(3) 21.7 A for AS/NZS 4777.2
(4) Can be achieved only if PV and battery power are sufficient.



Three-phase Hybrid Inverter

HYT-5.0HV-EUG1
HYT-6.0HV-EUG1
HYT-8.0HV-EUG1
HYT-10.0HV-EUG1
HYT-12.0HV-EUG1

The HYT-HV Series is a high-performance three-phase hybrid inverter with excellent reliability, including power classes ranging from 5 kW to 12 kW.

The intelligent EMS function supports self-consumption mode, economic mode, and backup mode for multi-scenario applications.

Monitoring management through S-Miles Cloud allows users to remotely diagnose and track the individual system's performance over time, offering superior energy production.



✔ Intelligent export limitation and 100% three-phase imbalanced output

✔ Double MPPT tracker, up to 14 A MPPT current

✔ Compatible with multiple batteries, providing users with more choices

✔ UPS level switching time <10 ms

✔ DC/AC ratio up to 150%

✔ Ultralight for easy installation and space-saving

✔ Built-in dry contact flexibly set to earth fault alarm, load control or generator control

✔ Max. 10 parallel inverters

Technical Specifications

Model	HYT-5.0HV-EUG1	HYT-6.0HV-EUG1	HYT-8.0HV-EUG1	HYT-10.0HV-EUG1	HYT-12.0HV-EUG1
Battery					
Battery Type	Li-ion				
Nominal Battery Voltage (V)	500				
Voltage Range (V)	170-600				
Max. Charge Current (A)	20	20	30	30	30
Max. Discharge Current (A)	20	20	30	30	30
Rated Power (W)	5000	6000	8000	10000	10000
Charging Strategy	Self-adaption to BMS				
PV Input					
Max. PV Input Power (W)	7500	9000	12000	15000	15000
Max. PV Input Voltage (V)	1000				
Nominal Input Voltage (V)	720				
MPPT Voltage Range (V)	200-950				
Start-up Voltage (V)	250				
Number of MPPTs	2				
Max. Number of PV String per MPPT	1/1	1/1	1/1	1/2	1/2
Max. PV Input Current (A)	14/14	14/14	14/14	14/28	14/28
Short-circuit Current of PV Input (A)	17/17	17/17	17/17	17/34	17/34
AC Input and Output (On-grid)					
Nominal Output Apparent Power (VA)	5000	6000	8000	10000	12000
Max. Output Apparent Power (VA)	5500	6600	8800	11000	12000
Max. Input Apparent Power (VA)	10000	12000	16000	16000	16000
Nominal AC Voltage (V)	400/380, 3L/N/PE				
Nominal Grid Frequency (Hz)	50/60				
Max. Output Current (A)	8.3	10.0	13.3	16.7	17.4
Max. Input Current (A)	15.2	18.2	24.2	24.2	24.2
Power Factor	0.8 leading ... 0.8 lagging				
Total Harmonic Distortion (@nominal output)	<3%				
AC Output (Off-grid)					
Max. Output Apparent Power (VA)	5000	6000	8000	10000	12000
Peak Output Apparent Power (VA)	10000, 10s	12000, 10s	16000, 10s	16000, 10s	16000, 10s
Nominal AC Voltage (V)	400/380, 3L/N/PE				
Nominal AC Frequency (Hz)	50/60				
Max. Output Current (A)	8.3	10.0	13.3	16.7	17.4
Total Harmonic Distortion (@linear load)	<3%				
Efficiency					
Max. Efficiency	98.0%	98.0%	98.0%	98.0%	98.0%
Euro Efficiency	97.0%	97.1%	97.2%	97.4%	97.5%
Max. Battery to Load Efficiency	97.5%	97.5%	97.5%	97.5%	97.5%
MPPT Efficiency	99.9%	99.9%	99.9%	99.9%	99.9%
Protection					
Anti-islanding Protection	Integrated				
PV String Input Reverse Polarity Protection	Integrated				
Insulation Resistor Detection	Integrated				
Residual Current Monitoring Unit	Integrated				
AC Over Current Protection	Integrated				
AC Short Current Protection	Integrated				
AC Overvoltage and Undervoltage Protection	Integrated				
Surge Protection	DC Type II / AC Type III				
General					
Dimension (W × H × D [mm])	502 × 486 × 202				
Weight (kg)	26.5				
Mounting	Wall Mounting				
Operation Temperature (°C)	-25 to + 65 (>45, derating)				
Relative Humidity	0-95%, no condensing				
Altitude (m)	≤2000				
Cooling	Natural convection				
Protection Degree	IP65				
Noise (dB [A])	<40				
User Interface	LED & App				
Communication with BMS	RS485, CAN				
Communication with Meter	RS485				
Communication Interface	RS485, Wi-Fi/Ethernet/4G (optional)				
Digital Input/output	DRM, 1 × DI, 2 × DO				
Isolation Method (Solar/Battery)	Transformerless / Transformerless				
Certifications and Standards					
Grid Regulation	EN 50549, VDE-AR-N 4105, AS/NZS 4777.2, VFR: 2019, TOR Erzeuger Type A, RD647, NTS (SENP), CEI 0-21 2019:04				
Safety Regulation	IEC 62109-1, IEC 62109-2				
EMC	EN 61000-6-1, EN 61000-6-3				



Single-phase AC-coupled Inverter

HAS-3.0LV-EUG1
HAS-3.6LV-EUG1
HAS-4.6LV-EUG1
HAS-5.0LV-EUG1

The HAS-LV-EUG1 Series is designed for retrofitting PV systems, including power classes ranging from 3 kW to 5 kW. It can be installed with existing PV inverters, forming an AC coupling system.

The intelligent EMS function supports self-consumption mode, economic mode, and backup mode for multi-scenario applications.

Moreover, the remote monitoring management through S-Miles Cloud allows users to track the full status of the system operation over time, maximizing power and energy utilization.



✔ Intelligent export limitation

✔ Ultralight for easy installation and space-saving

✔ Compatible with multiple batteries, providing users with more choices

✔ Built-in dry contact flexibly monitors earth fault alarm and provides load control or generator control

✔ UPS level switching time <10 ms

✔ Max. 10 parallel inverters

Technical Specifications

Model	HAS-3.0LV-EUG1	HAS-3.6LV-EUG1	HAS-4.6LV-EUG1	HAS-5.0LV-EUG1
Battery				
Battery Type	Li-ion / Lead-acid			
Nominal Battery Voltage (V)	48			
Voltage Range (V)	40-60			
Max. Charge Current (A)	75	90	100	100
Max. Discharge Current (A)	75	90	100	100
Max. Power (W)	3000	3600	4600	5000
Charging Strategy for Li-ion Battery	Self-adaption to BMS			
Charging Curve	3 Stages / Equalization			
External Temperature Sensor	Optional			
AC Input and Output (On-grid)				
Nominal Output Apparent Power (VA)	3000	3680	4600	5000 ⁽¹⁾
Max. Output Apparent Power (VA)	3000	3680	4600 ⁽²⁾	5000 ^{(1) (2)}
Max. Input Apparent Power (VA)	6000	7360	7360	7360
Nominal AC Voltage (V)	230			
Nominal Grid Frequency (Hz)	50 / 60			
Max. Output Current (A)	13.0	16.0	20.0	21.7
Max. Input Current (A)	26.1	32.0	32.0	32.0
Power Factor	0.8 leading ... 0.8 lagging			
Total Harmonic Distortion (@ nominal output)	< 3%			
AC Output (Off-grid)				
Max. Output Apparent Power (VA)	3000	3680	4600	5000
Peak Output Apparent Power (VA)	3300, 10s	4048, 10s	5060, 10s	5500, 10s
Nominal AC Voltage (V)	230			
Nominal AC Frequency (Hz)	50 / 60			
Max. Output Current (A)	13.0	16.0	20.0	21.7
Total Harmonic Distortion (@ linear load)	< 3%			
Efficiency				
Max. Efficiency	95.2%	95.2%	95.2%	95.2%
Protection				
Anti-islanding Protection	Integrated			
AC Over Current Protection	Integrated			
AC Short Current Protection	Integrated			
AC Overvoltage and Undervoltage Protection	Integrated			
Surge Protection	DC Type II / AC Type III			
General				
Dimensions (W × H × D [mm])	502 × 461 × 202			
Weight (kg)	21			
Mounting	Wall Mounting			
Operation Temperature (°C)	-25 to +65 (> 45, derating)			
Relative Humidity	0-95%, no condensing			
Altitude (m)	< 2000			
Cooling	Natural Convection			
Protection Degree	IP65			
Noise (dB [A])	< 40			
User Interface	LED & App			
Communication with BMS	RS485, CAN			
Communication with Meter	RS485			
Communication Interface	RS485, Wi-Fi/Ethernet/4G (optional)			
Digital Input/Output	DRM, 1 × DI, 2 × DO			
Isolation Method (Battery)	High-frequency Isolation			
Certifications and Standards				
Grid Regulation	EN 50549, VDE-AR-N 4105, AS/NZS 4777.2, VFR 2019, TOR Erzeuger Type A			
Safety Regulation	IEC 62109-1, IEC 62109-2, IEC 62477-1			
EMC	EN 61000-6-1, EN 61000-6-3			

(1) 4600 for VDE-AR-N 4105 & VDE0126-1-1; 4999 for AS/NZS 4777.2
 (2) Max. output apparent power 3680 VA for TOR Erzeuger Type A



Three-phase AC-coupled Inverter

HAT-5.0HV-EUG1
HAT-6.0HV-EUG1
HAT-8.0HV-EUG1
HAT-10.0HV-EUG1

The HAT-HV-EUG1 Series is designed for retrofitting PV systems, including power classes ranging from 5 kW to 10 kW. It can be installed with existing PV inverters, forming an AC coupling system.

The intelligent EMS function supports self-consumption mode, economic mode, and backup mode for multi-scenario applications.

Moreover, the remote monitoring management through S-Miles Cloud allows users to track the full status of the system operation over time, maximizing power and energy utilization.



- ✔ Intelligent export limitation and 100% three-phase imbalanced output
- ✔ Compatible with multiple batteries, providing users with more choices
- ✔ UPS level switching time <10 ms
- ✔ Ultralight for easy installation and space-saving
- ✔ Built-in dry contact flexibly set to earth fault alarm, load control or generator control
- ✔ Max. 10 parallel inverters

Technical Specifications

Model	HAT-5.0HV-EUG1	HAT-6.0HV-EUG1	HAT-8.0HV-EUG1	HAT-10.0HV-EUG1
Battery				
Battery Type	Li-ion			
Nominal Battery Voltage (V)	500			
Voltage Range (V)	170-600			
Max. Charge Current (A)	20	20	30	30
Max. Discharge Current (A)	20	20	30	30
Max. Power (W)	5000	6000	8000	10000
Charging Strategy	Self-adaption to BMS			
AC Input and Output (On-grid)				
Nominal Output Apparent Power (VA)	5000	6000	8000	10000
Max. Output Apparent Power (VA)	5500	6600	8800	11000
Max. Input Apparent Power (VA)	10000	12000	16000	16000
Nominal AC Voltage (V)	400/380, 3L/N/PE			
Nominal Grid Frequency (Hz)	50/60			
Max. Output Current (A)	8.3	10.0	13.3	16.7
Max. Input Current (A)	15.2	18.2	24.2	24.2
Power Factor	0.8 leading ... 0.8 lagging			
Total Harmonic Distortion (@nominal output)	< 3%			
AC Output (Off-grid)				
Max. Output Apparent Power (VA)	5000	6000	8000	10000
Peak Output Apparent Power (VA)	10000, 10s	12000, 10s	16000, 10s	16000, 10s
Nominal AC Voltage (V)	400/380, 3L/N/PE			
Nominal AC Frequency (Hz)	50/60			
Max. Output Current (A)	8.3	10.0	13.3	16.7
Total Harmonic Distortion (@ linear load)	< 3%			
Efficiency				
Max. Efficiency	97.5%	97.5%	97.5%	97.5%
Protection				
Anti-islanding Protection	Integrated			
AC Over Current Protection	Integrated			
AC Short Current Protection	Integrated			
AC Overvoltage and Undervoltage Protection	Integrated			
Surge Protection	DC Type II / AC Type III			
General				
Dimensions (W × H × D [mm])	502 × 486 × 202			
Weight (kg)	23			
Mounting	Wall Mounting			
Operating Temperature Range (°C)	-25 to + 65 (> 45, derating)			
Relative Humidity	0-95%, no condensing			
Altitude (m)	< 2000			
Cooling	Natural Convection			
Protection Degree	IP65			
Noise (dB [A])	< 40			
User Interface	LED & App			
Communication with BMS	RS485, CAN			
Communication with Meter	RS485			
Communication Interface	RS485, Wi-Fi/Ethernet/4G (optional)			
Digital Input/Output	DRM, 1 × DI, 2 × DO			
Isolation Method (Battery)	Transformerless			
Certifications and Standards				
Grid Regulation	EN 50549, VDE-AR-N 4105, AS/NZS 4777.2, VFR 2019, TOR Erzeuger Type A			
Safety Regulation	IEC 62109-1, IEC 62109-2, IEC 62477-1			
EMC	EN 61000-6-1, EN 61000-6-3			



Data Transfer Stick

DTS-WIFI-G1

DTS-Ethernet-G1

DTS-4G-G1

Hoymiles gateway DTS series are data transfer sticks that work between inverters and S-Miles Cloud platform via Wi-Fi, Ethernet or 4G communication. The DTS is designed as a suitable option for the energy storage system.

Hoymiles DTS is small and easy to install. It pairs with the S- Miles Cloud platform to enable real-time system data or alarm monitoring and allows remote operation and maintenance of the storage energy system from anywhere.



✓ Integrated to use, simply plug and play

✓ Stable and reliable data transmission

✓ IP65 protection

✓ Remote maintenance of energy storage system on S-Miles Cloud platform

Technical Specifications



Model	DTS-WIFI-G1
Communication	
Max. Inverter Supported	10
Sample Rate	15 minutes
Indicator	LED
Connection Interface	USB
Wireless Standard	802.11b/g/n
Frequency Range	2.412 GHz - 2.484 GHz
Configuration Method	App / Web
General	
Operating Voltage	DC 5 V
Power Consumption	≤ 5 W
Dimensions (W × H × D)	108 × 57 × 36 mm (4.3 × 2.2 × 1.4 inch)
Weight	60 g (0.13 lb)
Protection Degree	IP65
Installation Method	Insert + Screw
Environment	
Operating Temperature Range	-25°C to 65°C (-13°F to 149°F)
Relative Humidity	0-95%, no condensing
Operating Altitude	≤ 4000 m
Certifications and Standards	
Certificate	CE / RCM

Technical Specifications

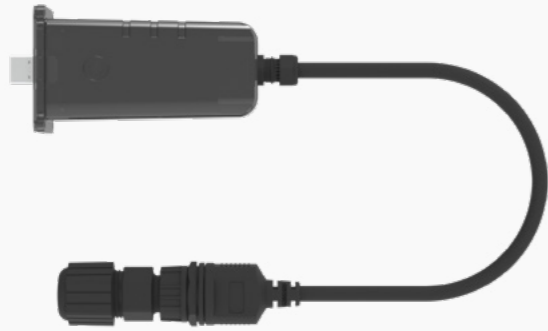

Model	DTS-Ethernet-G1
Communication	
Max. Inverter Supported	10
Sample Rate	15 minutes
Indicator	LED
Connection Interface	USB
Ethernet Interface	RJ45
Ethernet Interface Standard	10Base-T / 100Base-T
Max. Distance of Network Cable	80 m
Configuration Method	App / Web
General	
Operating Voltage	DC 5 V
Power Consumption	≤ 5 W
Dimensions (W × H × D)	108 × 57 × 36 mm (4.3 × 2.2 × 1.4 inch)
Weight	130 g (0.22 lb)
Protection Degree	IP65
Installation Method	Insert + Screw
Environment	
Operating Temperature Range	-25°C to 65°C (-13°F to 149°F)
Relative Humidity	0-95%, no condensing
Operating Altitude	≤ 4000 m
Certifications and Standards	
Certificate	CE / RCM

Technical Specifications



Model	DTS-4G-G1
Communication	
Max. Inverter Supported	10
Sample Rate	15 minutes
Indicator	LED
Connection Interface	USB
4G Standard & Frequency Range	4G: LTE-FDD / LTE-TDD 3G: WCDMA / HSDPA / HSUPA / HSPA+ 2G: GSM / GPRS / EDGE
Configuration Method	App / Web
General	
Operating Voltage	DC 5 V
Power Consumption	≤ 5 W
Dimensions (W × H × D)	108 × 57 × 36 mm (4.3 × 2.2 × 1.4 inch)
Weight	80 g (0.18 lb)
Protection Degree	IP65
Installation Method	Insert + Screw
Environment	
Operating Temperature Range	-25°C to 65°C (-13°F to 149°F)
Relative Humidity	0-95%, no condensing
Operating Altitude	≤ 4000 m
Certifications and Standards	
Certificate	CE / RCM



Rapid Shutdown Device HRSD-1C Series



As part of Hoymiles rapid shutdown solution for PV system, HRSD-1C can be connected with one module. It meets NEC 2017, NEC 2020, UL 1741 and SunSpec Rapid Shutdown requirements, guaranteeing PV system safety.

The HRSD device enables proper operation of the PV system when it is installed and receives a "permission to operate" signal from the Hoymiles Transmitter. In an emergency, PV system would enter module-level rapid shutdown mode by simply disconnecting the AC power of Transmitter or using an external initiator.



Triple Safety Design

Active Bypass Technology

- 
Module-level rapid shutdown
 Meets SunSpec RSD, NEC 2017&NEC 2020 690.12 requirements
- 
Increased Reliability
 Uses Active Bypass to reduce heat generation in shade and other situations
- 
Better Temperature Uniformity
 Uses graphene heat spreader to improve heat dissipation

- 
Easy Installation
 Plug & play, no configuration required
- 
High Efficiency
 Lower power consumption and wider operating voltage range
- 
Reliable Communication
 Able to avoid crosstalk with special communication modulation technique

Technical Specifications

Model	HRSD-1C	HRSD-1C-B
Electrical Data		
Input Voltage Range	13-80 V	13-65 V
Maximum Current	15 A	20 A
Maximum Short Circuit Current	25 A	
Maximum System Voltage	1000/1100 V (1500 V optional)	
Communication Type	SunSpec PLC	
Shutdown Output Voltage	1 V	
Power Consumption	200 mW	
Mechanical Data		
Input Connectors	MC4 / MC4 EVO2, Customisable	
Input Cable Length	0.15 m (0.49 ft.) , Customisable	
Output Connectors	MC4 / MC4 EVO2, Customisable	
Output Cable Length	1.2 m (3.94 ft.) ¹ , Customisable	
Dimensions	113 x 54 x 16 mm (4.45 x 2.13 x 0.63 inch)	
Environmental		
Operating Temperature Range	-40°C to +85°C (-40°F to +185°F)	
Outdoor Rating	IP68 / NEMA6P	
Compliance		
Safety	UL1741, CSA C22.2 No. 330-17, IEC/EN 62109-1	
EMC	FCC Part15 Class B, ICES-003, IEC/EN 61000-6-1/-2/-3/-4	

*1: Fits PV module in landscape and portrait installation.

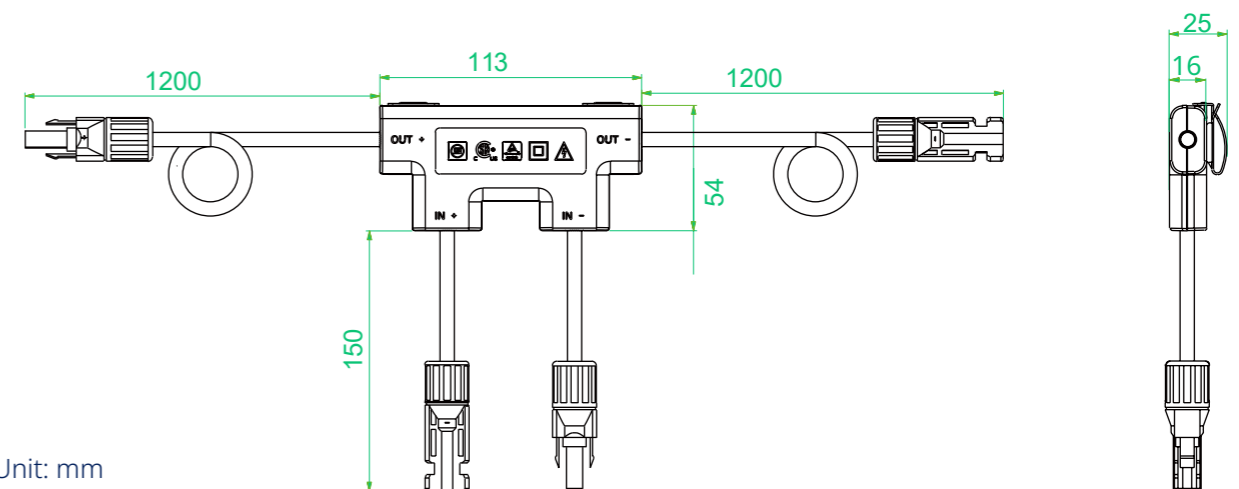

Unit: mm



Rapid Shutdown Device HRSD-2C Series

As part of Hoymiles rapid shutdown solution for PV system, HRSD-2C can be connected with two modules. It meets NEC 2017, NEC 2020, UL 1741 and SunSpec Rapid Shutdown requirements, guaranteeing PV system safety.

The HRSD device enables proper operation of the PV system when it is installed and received a "permission to operate" signal from the Hoymiles Transmitter. In an emergency, PV system would enter module-level rapid shutdown mode by simply disconnecting the AC power of Transmitter or using an external initiator.



Triple Safety Design

Active Bypass Technology

✓ **Module-level rapid shutdown**
Meets NEC 2017&NEC 2020 690.12 requirements and SunSpec RSD requirements

✓ **Cost-effective**
Two inputs

✓ **PLC communication**
Realize rapid shutdown with Transmitter

✓ **Easy Installation**
Plug & play, no configuration required

✓ **High Efficiency**
Lower power consumption and wider operating voltage range

✓ **Low Noise**
Much lower than arc noise. No risk of triggering AFCI

Technical Specifications

Model	HRSD-2C		
Electrical Data			
Output Voltage Range	16-160 V		
Input Voltage Range	8-80 V	8-65 V	8-50V
Maximum Current	15 A	20 A	25 A
Maximum System Voltage	1000 V (1500 V optional)		
Communication Type	SunSpec PLC		
Shutdown Output Voltage	1 V		
Power Consumption	200 mW		
Mechanical Data			
Input Connectors	MC4 / MC4 EVO2, Customisable		
Input Cable Length	0.45 m (1.48 ft.), Customisable		
Output Connectors	MC4 / MC4 EVO2, Customisable		
Output Cable Length	2.4 m (7.87 ft.) ¹ , Customisable		
Dimensions	133 x 58 x 16 mm (5.24 x 2.28 x 0.63 inch)		
Environmental			
Operating Temperature Range	-40°C to +85°C (-40°F to +185°F)		
Outdoor Rating	IP68 / NEMA6P		
Compliance			
Safety	UL1741, CSA C22.2 No. 330-17, IEC/EN 62109-1		
EMC	FCC Part15 Class B, ICES-003, IEC/EN 61000-6-1/-2/-3/-4		

*1 Fits PV module in landscape and portrait installation.

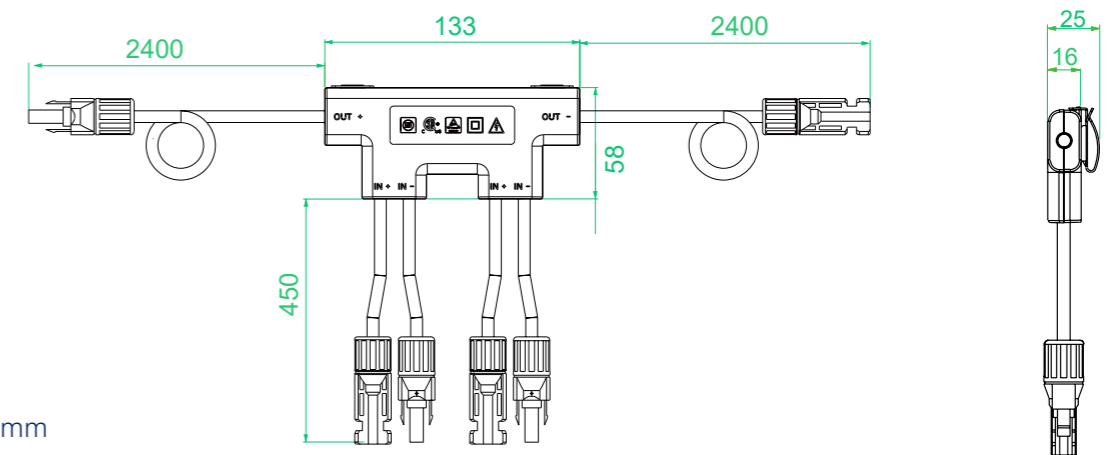

Unit : mm



Transmitter

HT10-Kit

Hoymiles Transmitter HT10-Kit is part of Hoymiles Rapid Shutdown solution and works with HRSD for module-level rapid shutdown.

While powered on, the HT10-Kit uses PLC technology to continuously send a "permission to operate" signal to HRSD, enabling the PV system to start producing power. In case of emergency, the PV system would enter module-level rapid shutdown mode by simply disconnecting the AC power of Transmitter or using an external initiator.

Hoymiles Transmitter Outdoor Kit includes one Transmitter, single or dual Core, single- or three-phase power supply, and outdoor enclosure.



- ✓ Module-level rapid shutdown with Hoymiles HRSD
- ✓ Achieves rapid shutdown through Transmitter power-off or external initiation
- ✓ Equipped with single/dual Core

- ✓ Complied with NEC 2017&NEC 2020 (690.12) and SunSpec RSD requirements
- ✓ Weatherproof outdoor enclosure
- ✓ Equipped with single- / three-phase power supply

Technical Specifications

Model	HT10-Kit									
Electrical										
Transmitter Input Voltage	12 VDC (+/-2%)									
Transmitter Input Current	1 A									
Input Voltage Range	85-264 VAC	180-550 VAC			180-550 VAC					
Communication Type	SunSpec PLC									
Core										
Number of Configure Core	1			1			2			
Max. Current per Core	75 A			150 A			150 A			
DC Cable Diameter	Φ 6 mm	Φ 6.45 mm	Φ 7 mm	Φ 6 mm	Φ 6.45 mm	Φ 7 mm	Φ 6 mm	Φ 6.45 mm	Φ 7 mm	
Max. Number of Strings per Core ¹	5	4	3	15	12	10	15	12	10	
Mechanical										
Dimensions	93 x 36.5 x 53 mm (3.66 x 1.44 x 2.09 inch)									
Mounting Type	DIN35 Rail									
Environmental										
Operating Temperature Range	-40°C to +85°C (-40°F to +185°F)									
Outdoor Rating	IP30 / NEMA1									
Compliance										
Safety	UL1741, CSA C22.2 No. 330-17									
EMC	FCC Part15 Class B, ICES-003									

*1: The maximum number of strings per Core is determined by the DC cable current and diameter. The total current should not exceed the Core's maximum allowed current, and the total cable diameter should not exceed the Core's diameter. If the actual cable diameter exceeds the reference diameter, the maximum number of strings per Core will be reduced accordingly.

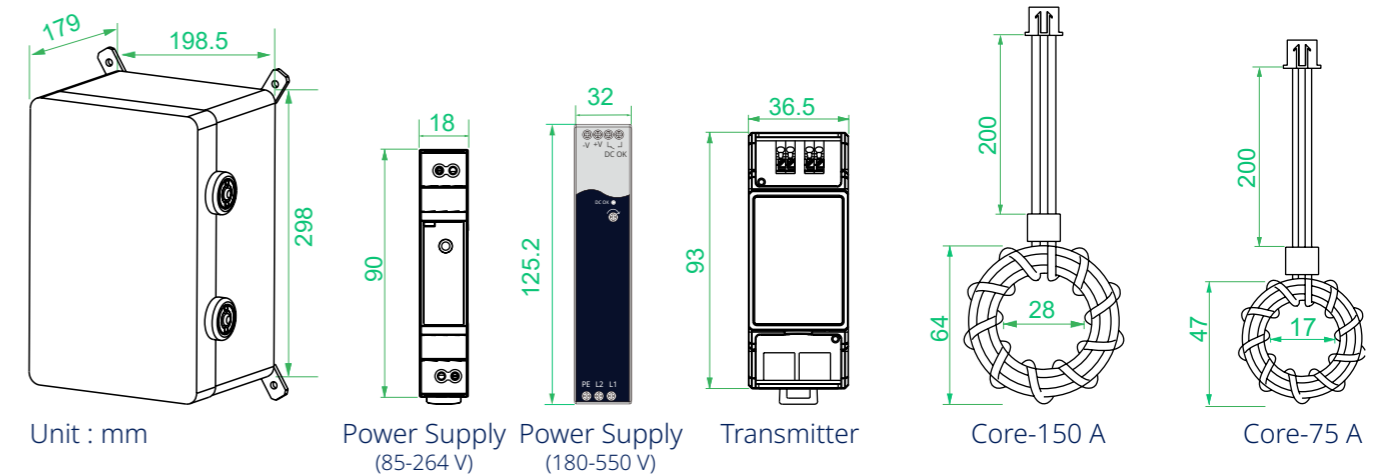



S-Miles Cloud

- Module level monitoring
- Individual MPPT
- Easy to operation and maintain the system

Available:

- ✓ Webpage
- ✓ APP- Android / IOS

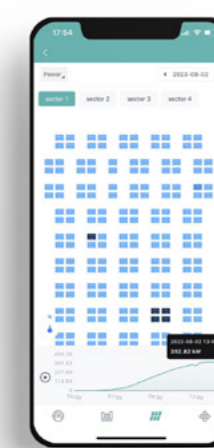
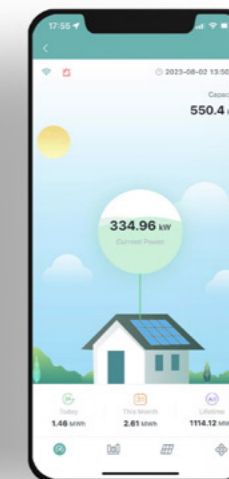
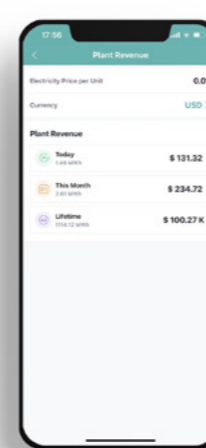
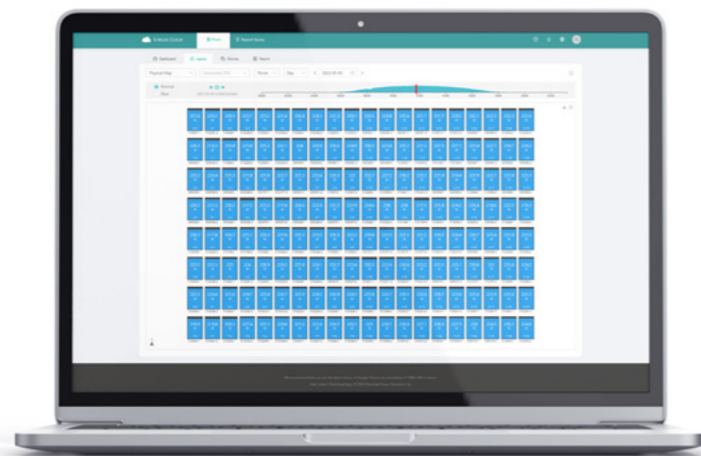



Floating Project

Hoymiles floating project was completed in Israel in 2022. It's a 300kW Project with the remarkable module-level monitoring capacity. HMS-1800 microinverters are working under water to power the whole system.

How can Hoymiles help with your floating solar system?

In the next few years, floating solar panels are probably going to go from being quite rare to being the norm all over the world. And no wonder: They cut out lots of the drawbacks of land-based solar system and provide some extra benefits of their own too.

But they're definitely harder to install and maintain than traditional solar panels – which means that, if you want to get the most out of them, you'll need to choose every component of your system very carefully.

At Hoymiles, we're known around the world for reliable, robust microinverters. Microinverters that

not only convert solar energy from DC to usable AC power with incredible efficiency but which are also built to hold up against the elements.

Hoymiles microinverters are:

- IP67 rated, and built to resist both water and damaging solids like dirt and debris. Crucially, all of our microinverters are compliant with corrosion resistance standards like ISO 9223:2012, and are classified as C5 “very high” anti-corrosivity – so you can have complete confidence in their performance, whether your solar system is installed inland or near the coastline.
- Built with aluminium alloy covers and a durable powder coating, designed to withstand anything the world – or the water – can throw at them.
- Tested thoroughly – we even put them through a 500-hour salt spray test to make sure they can survive in seawater too. We also test their performance in a variety of environments, including temperate and subtropical zones and atmospheric environments with very high pollution or chloride concentrations (such as industrial areas, coastal areas, and sheltered positions on coastlines).
- Designed to work underwater as well as above the surface.

In fact, our microinverters are already delivering results at a 300 kW floating solar system in Israel, providing outstanding efficiency and total reliability every day.

259.2kW

Bangkok, Thailand
HM-1500
2023.01



Commercial Project Cases

Capacity: **390 kW**

Location: Bangkok, Thailand

HMS-2000-4T

2020.04



Capacity: **300kW**

Location: Bangkok, Thailand

HMS-2000-4T

2023.05



Capacity: **250kW**

Location: Ayutthai, Thailand

MI-1500

2020.03



Residential Project Cases

Capacity: **53 kW**
Location: Cainta, Philipines
HMS-2000-4T
2023.07



Residential Project Cases

Capacity: **27 kW**
Location: Jawa Barat, Indonesia
HMS-1800-4T
2022.06



Capacity: **100 kW**
Location: Canberra, Australia
HME-1200-AU
2022.06



Capacity: **23.76 kW**
Location: Johannesburg, SouthAfrica
MI-1200
2019.07



Worldwide Project Cases

Farm Project

Capacity: **281kW**

Location: Central Missouri, US



Capacity: **12kW**

Location: Sao Paulo



Capacity: **31.5kW**

Location: Nova Scotia, Canada



Worldwide Project Cases

Capacity: **3.6kW**

Location: Saubens, France



Capacity: **158kW**

Location: Johannesburg, South Africa



Capacity: **63.6kW**

Location: Pärnu county, Estonia



Contact Details

Headquarters:

Hoymiles Power Electronics Inc.
Floor 6, Building 5, 99 Housheng Road,
Gongshu District, Hangzhou

US Sales and Support Center:

Plano, Texas, 75074

Europe Sales and Support Center:

High Tech Campus 9, Unit BK3.28, 5656AE Eindhoven, the Netherlands

hoymiles.com

86 571 2805 6101

info@hoymiles.com

sales@hoymiles.com

support@hoymiles.com

[LinkedIn](#) | [Facebook](#) | [Twitter](#) | [YouTube](#)

